

Backscatter Immersion Process Probe

Applications:

- **Crystallization control**
- **Fermentation control**
- **Cell culture & biomass monitoring**
- **Interface detection**

The Kemtrak backscatter immersion probe is designed to accurately measure suspended solids directly in tanks and pipelines. The immersion probe has the same dimensions as industry standard Ø12 mm PG 13.5 pH sensors allowing a range of standard fittings and retractable probe holders to be used.

The dual fiber optic design of the immersion probe provides high resolution at low turbidity with excellent linearity all the way up to extremely high turbidity when used with a Kemtrak NBP007 near-infrared backscatter photometer.

A unique benefit of the Kemtrak backscatter immersion probe is that it does not go blind at high sample turbidity. Other probes will stop working at 4000 NTU/FNU (<1 wt% solids) after which the signal will decrease resulting in an erroneous and misleading output. The output of the Kemtrak probe will continue to increase with sample concentration ensuring a reliable measurement.

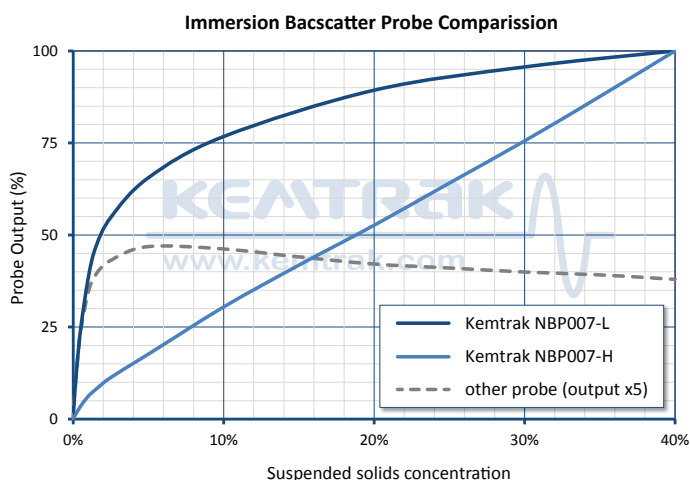

The compact design of the immersion probe makes the instrument suitable for laboratory bench-top work to the most demanding commercial process installations.

Standard probe design is in 316L stainless steel or Hastelloy C-22 with a robust scratch resistant sapphire window. The highly polished probe surface ensures freedom from fouling and suitability for sanitary applications.

The fiber optic immersion probe has no electronics that will be damaged by high temperature process streams or sterilization cycles and are well suited for both ordinary and hazardous area installation. Retractable probe holders can be used for automated cleaning and validation.

All Kemtrak products are designed to meet the most demanding application specifications and are made from the highest quality materials to ensure exceptionally long life and the highest reliability possible.



KEATRak

www.kemtrak.com

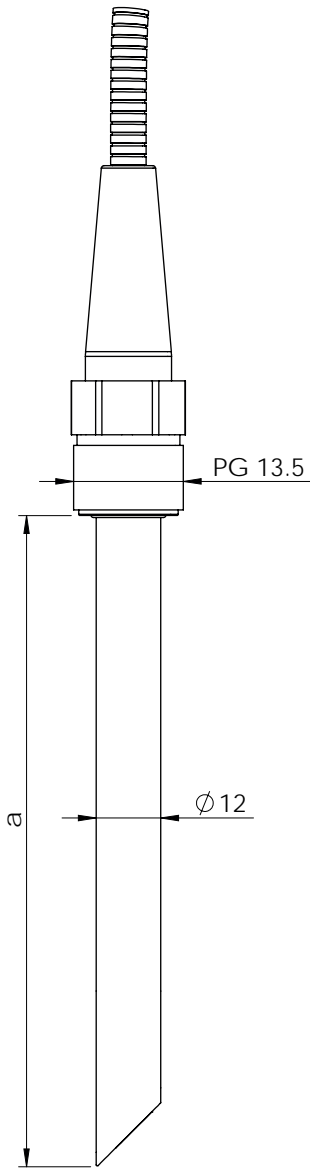

Benefits:

- 0.001% (ca. 10 NTU) to 100% total suspended solids
- Compatible with industrial pH sensor dimensions (DIN 19263:2007-05)
- Probe lengths (a) 120mm, 225mm, 325mm & 425mm
Other lengths available on request
- Sapphire window is mounted from inside of probe and sealed using o-rings (no epoxy) - impossible to fall out in the process
- Suitable for ordinary and hazardous area installation

Technical Data Immersion Backscatter Probe

Measurement Range

0.001% (ca. 10NTU) to 100% total suspended solids

Manifold

Compatible with industrial pH sensor dimensions
DIN 19263:2007-05, Ø 12 mm, PG 13.5
Standard probe length 120 ± 2 mm, 225 mm, 325 mm & 425 mm
Custom lengths available on request

Materials

Stainless EN 1.4435 / 316L or
Hastelloy C-22

Window

Sapphire

Surface Finish

Ra < 0.38 µm

Elastomers

FPM (FKM/Viton®), FFKM (Chemraz®/Kalrez®, FDA), EPDM (FDA)

Operating Conditions

Ambient & process temperatures up to 200°C (392°F)
Process pressure from 10mbar to 50 bar (0,14 – 725 psi)
Operating conditions subject to material and design in use

Fibre Optic cable

Silica core photonic fiber with Kevlar® reinforced flexible
LZSH coated stainless steel jacket
Fully-interlocked stainless steel conduit for use above 85°C (185°F)
Terminated with SMA 905 connectors
5 m standard (16.4 ft)
Lengths up to 20m (66 ft)

Protection

IP66 / EN 60529

Recommended Controller

Kemtrak NBP007 backscatter photometer

KEMTRAK
www.kemtrak.com

Kemtrak AB • SE 187 66 Stockholm • Sweden
sales@kemtrak.com • www.kemtrak.com

*We reserve the right to make changes
without prior notice*

Distributor

Kemtrak is a leading manufacturer of fiber optic measuring and automation products for the process engineering industry. Kemtrak provides tailor made solutions to meet the needs of a wide range of industries including chemical, petrochemical & offshore, biotech, pharmaceutical, food & beverage, pulp and paper and water & environment. Kemtrak has trained representatives and support personnel globally and is certified according to ISO 9001:2015.